

OPTIMIZING THE AIR VELOCITY IN AN INDUSTRIAL WOOD DRYING PROCESS

YLVA STEINER

NORWEGIAN UNIVERSITY OF LIFE SCIENCES
DEPARTMENT OF ECOLOGY AND NATURAL RESOURCE MANAGEMENT
MASTER THESIS 30 CREDITS 2008



Preface

This is my master thesis at the Department of Ecology and Natural Resource Management (INA) at the Norwegian University of Life Sciences (UMB). This master thesis is a part of the project “Produktrettet effektivisering av tørkeprosessen” at Tørkeklubben and Norsk Treteknisk Institutt.

First I would like to thank Tørkeklubben and Norsk Treteknisk Institutt for letting me be a part of their project and financing this master thesis. Although it is only my name written on the front page, there have been others highly involved in both the laboratory work and the writing process. I would like to thank my supervisors; Geir I. Vestøl, at University of Life Sciences, and Knut Magnar Sandland, at Norsk Treteknisk Institutt. Geir, for priceless help with the statistics and writing. Knut Magnar, my living dictionary in wood drying, for guiding me through the whole process, from planning the experiment to putting the finishing touches on the written work. I also want to thank Romerike Trelast for providing the lumber for my experiments and Henning Horn and Knut Finstad at Norsk Treteknisk Institutt, for all the help in the laboratory.

Ås, May 2008

Ylva Steiner

Abstract

For many years scientists and saw millers have tried to make drying of lumber more efficient. Many problems have been solved, but there still is a large potential for improving the efficiency of wood drying, especially in a time with increasing energy prices. The difference in energy prices and the relationship between fan speed and energy consumption justifies more studies on the possibilities for reducing air velocity during the drying process. Air velocity requirements should be smaller when all the free water is removed and only bound water is left. Fiber saturation point could therefore be a suitable point for lowering air velocity. During drying the boards dry faster near the surface than in the center. This leads to a moisture gradient in the cross section of the boards, making it possible to gradually reduce air velocity from 40 % moisture content, down to about 20 %, where after the air velocity does not influence the drying rate at all. In this study effects of air has been studied in order to find when and how much the air velocity can be reduced, without affecting the drying rate of the boards. 36 samples of 50 by 100 mm boards (2xlog) of Norway spruce (L. Karst. *Picea abies*) were dried at 70 °C with varying air velocity. Results show that a too early and/or too strong reduction in air velocity gives a reduced drying rate and a large variation in moisture content. A drying program with a gradually reduction in air velocity from 5 m/s at 40 % moisture content down to 0,6 m/s at 20 % gives a satisfying drying rate and variation in final moisture content. The results are based on a limited sample dried in a small-scale laboratory kiln with good control of the airflow. The study should be extended with similar tests in industrial kilns to find out how big safety margins needs to be used because of variation in both initial moisture content and air velocity in the kiln compartment.

Table of content

Preface.....	1
Abstract	2
1.0 Introduction	4
1.1 Water transport in wood	5
1.2 Water transport from lumber.....	7
1.4 Drying in practice	10
1.5 Need for information.....	12
2.0 Materials and methods.....	13
2.1 Material	13
2.2 Method	14
2.3 Statistical analysis	17
3.0 Results.....	19
3.1 Moisture content	19
3.2 Drying rate	21
3.3 Multiple regression model for drying rate.....	24
3.4 Effect of air velocity on single boards.....	26
4.0 Discussion	27
4.1 Moisture content	27
4.2 Effect of air velocity on drying rate for single boards.....	27
4.3 Effect of air velocity on drying rate for the investigated programs	27
4.4 Drying in practice	28
4.5 Practical example	29
4.6 Future work	30
5.0 Literature.....	31

1.0 Introduction

For many years scientists have tried to make drying of lumber more efficient. Earlier much effort was put into finding ways to shorten drying time and make the conditions in the drying chamber more uniform. Air velocity has been one important factor in that work. In more recent years focus has shifted and today there is interest in the possibility of reducing energy costs by reducing air velocity (Salin 2001b).

In 2006 the price for electrical power was 46.7 øre/kWh for the lumber industry in Norway, while bioenergy only costed 5.3 øre/kWh (Statistisk sentralbyrå). Since the fans in the dryer are the biggest consumer of electrical power in the sawmills (Esping 1996) the possibilities for reduction in air velocity is of great interest. Also small reductions in air velocity is justified by the relationship between fan speed and fan power consumption. A reduction in fan speed gives an even greater reduction in electrical use (figure 1) (Esping 1992, Salin 2001b, Vranizan 1986, Wengert 2006). Fan power can be described as the cube of fan speed (Esping 1992):

$$Fan \ power = f\left(fan \ speed^3\right) \quad (1)$$

P = power consumption of fan

V = fan speed

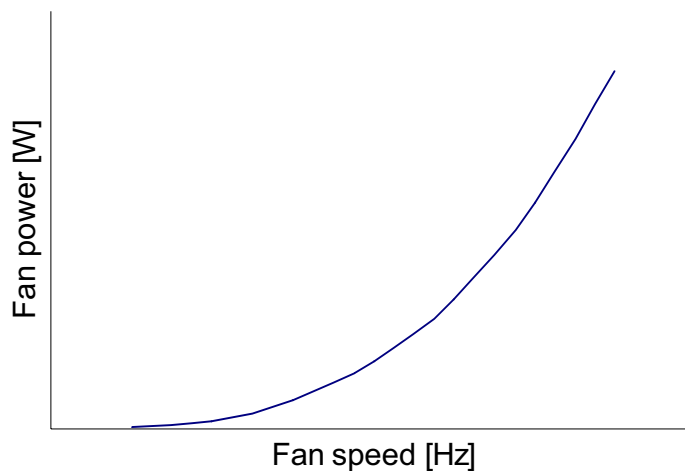

Figure 1. The relationship between fan speed and fan power (based on formula 1).

The difference in energy prices and the relationship between fan speed and energy consumption justifies more studies on the possibilities for reducing air velocity. Not much work has been done on this field over the years and the experiments that has been made is on wood species that are not commonly used in Scandinavian sawmills (Simpson 1997, Torgeson 1951).

Air velocity in the kiln has three functions: to transport moisture away from the lumber, transport heat to the lumber and to give uniform relative humidity and temperature throughout the kiln (Bachrich 1980, Eckelman & Baker 1976). There are many factors that influence the air's ability and the need for transportation of moisture, such as boundary layer, wood moisture content, moisture gradient, variation in both moisture content and air velocity in kiln etc.

1.1 Water transport in wood

There are two methods for water to transport in wood. Bound water diffuses through the cell walls and cell lumens, and free water transports with capillary forces through the voids in the wood structure. Diffusion is driven by a gradient of concentration (Esping 1992) and can be expressed by Fick's first law (Siau 1984):

$$D = \frac{w/tA}{\Delta c/L} \quad (2)$$

D = water-vapor diffusion coefficient of wood [cm^2/s]

w = mass of water vapor transferred through wood in time t [g]

A = cross-sectional area of specimen [cm^2]

L = length in flow direction [cm]

t = time [s]

Δc = concentration difference [g/cm^3]

The difference in concentration increases with decreasing relative humidity. Thus, diffusion increases when relative humidity is decreased. The rate of the capillary transport is dependent upon the permeability of the material (Esping 1992). Capillary transport of water in wood can be described by Darcy's law (Siau 1984):

$$k_g = \frac{QLP}{A\Delta P\bar{P}} \quad (3)$$

k_g = superficial gas permeability [cm^3]

Q = volumetric flow rate [cm^3/s]

L = length in flow direction [cm]

P = pressure at which flow rate is measured [atm]

A = cross-sectional area of specimen [cm^2]

ΔP = pressure differential [atm]

\bar{P} = arithmetic average pressure in the specimen [atm]

Both diffusion and capillary transport of water increases with temperature (Esping 1992). Capillary transport is much faster than diffusion, which leads to high transport of water when the lumber contains much free water and low transport when only bound water is left to remove (Esping 1992). Thus, air velocity requirements should be smaller when all the free water is removed and only bound water is left (Lamb 2002). Fiber saturation point could therefore be a suitable point for lowering air velocity (Torgeson 1951).

During drying the boards dry faster near the surface than in the center. This leads to a moisture gradient in the cross section of the boards (Esping 1992, Rosenkilde 1996). This means that the outer areas of the boards will reach fiber saturation before the average moisture content reaches 30 %. Thus, the water in these areas will diffuse out to the surface. This will inhibit the drying rate, making it possible to reduce air velocity before average moisture content reach fiber saturation point (figure 2). Lamb (2002) and Wengert (2006) talks about the possibility to gradually reduce air velocity from 40 % moisture content, down to about 20 %, where after the air velocity does not influence the drying rate at all. Other studies also set the limit for when air velocity increases drying rate to 40-50 % (Simpson 1997).

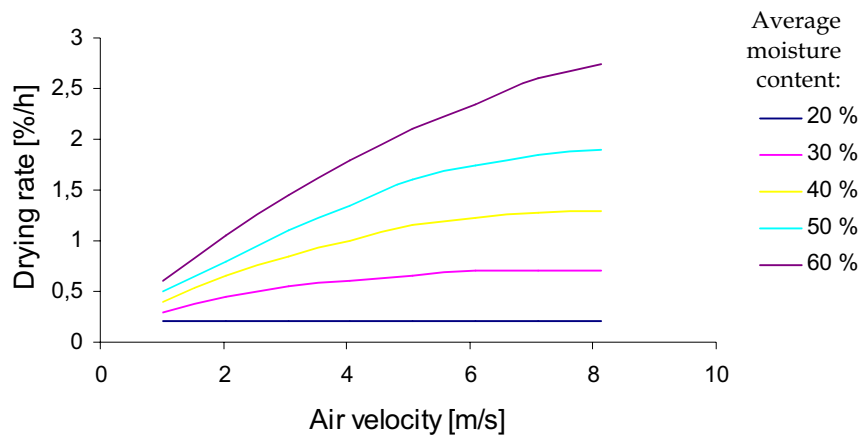

Figure 2. Effect of air velocity on the drying rate of sugar maple sapwood at a temperature of 54 °C (130 °F) and a relative humidity of 76 %. Based on the results from Torgeson (1951).

The possibility for reduction of air velocity should increase with board dimension. This is because the drying process is shorter for small dimensions giving less room for adjustments and during drying the moisture content gradient is smaller for small dimensions reducing the possibilities for lowering the air velocity at relatively high average moisture content.

Since a high density board has less room for free water and contains more bound water, and air velocity has less impact on dry boards with much bound water, air velocity should be more important for boards and species with low density.

1.2 Water transport from lumber

When air passes through a batch of moist lumber the air will absorb moisture from the lumber. After a while this air will be saturated with moisture (Esping 1996). To avoid this limitation this air will need to be replaced with new dry air. There is therefore a limit for how low air velocity that can be tolerated before the air gets saturated and the drying rate starts to slow down (figure 3). The relative humidity can also be used to control the drying rate. Air with low humidity can carry more water, thus increasing the time for the air to get saturated and the air velocity requirements are reduced. Air with high temperature also can bind more water, making it possible to have a lower air velocity, but at the same time high

temperature speeds up the water transport in the boards, leading to greater demand for air velocity (Esping 1992). As the lumber gets dryer in the drying process the amount of damp evaporating from the lumber will decrease leading to a longer time before the air is saturated. Therefore the air velocity requirements should reduce as the lumber dries (Simpson 1997, Wengert 2006).

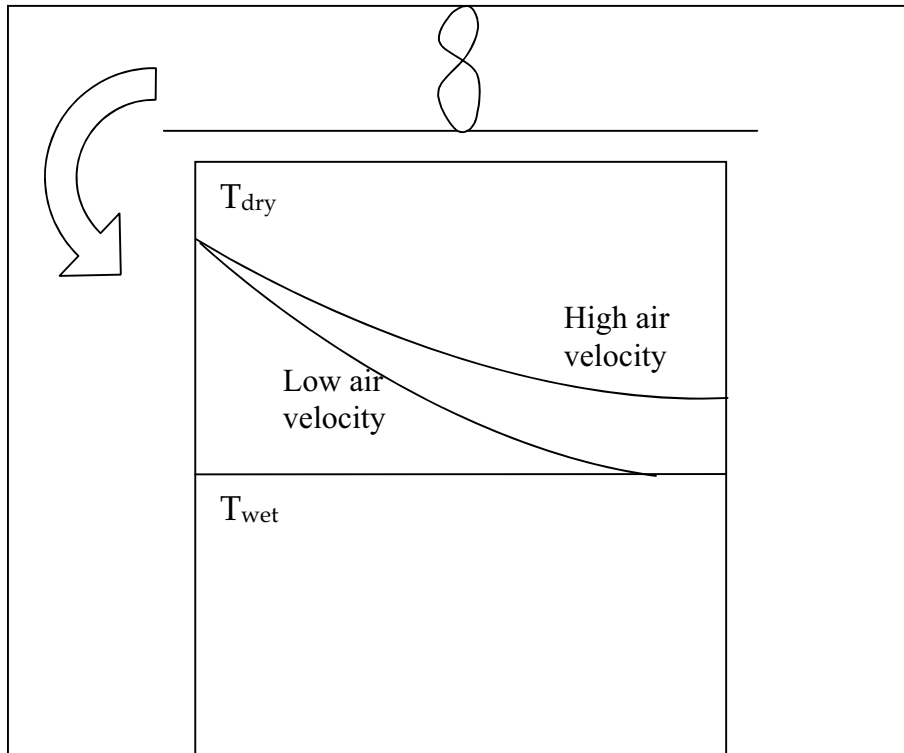

Figure 3. Dry and wet bulb temperature as it moves through a batch of moist lumber. At low air velocity air gets saturated before leaving the batch, which is not the case when the air velocity is high enough.

Another important factor for the air requirements is the boundary layer. This is the layer closest to the surface of the boards. If one considers the cross section of the sticker area between the layers in the batch, the air in the middle of the cross section will have the highest velocity. The closer you get to the surface the higher resistance the air meets and the velocity decreases to zero just above the board surface (figure 4) (Esping 1992). This leads to a boundary layer at the board surface where the air moves very slowly, causing a reduction in drying rate (Salin 2001b). When air enters over a surface the airflow is laminar, i.e. a linear flow in the flow direction. After a distance over the surface the airflow becomes turbulent. Reynolds number can be used to determine what flow will occur (Siau 1984):

$$\text{Re} = \frac{L\bar{v}\rho}{\eta} \quad (4)$$

L = length parallel to the surface along which the boundary layer is formed [cm]

\bar{v} = average velocity of bulk air relative to the surface [cm/s]

ρ = density of the fluid [g/cm³]

η = viscosity of the fluid [dyne s/cm²]

The critical number for turbulent flow in the boundary layer is 20,000 (Siau 1984) and either a high air velocity is needed for forming turbulent flow or a longer distance over the surface (figure 5).

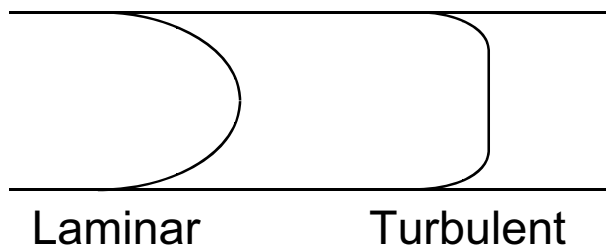

Figure 4. Shape of the air flow between to boards, showing that turbulent flow gives thinner boundary layer than laminar flow.

This turbulent flow makes the boundary layer thinner and thus making drying conditions better (figure 4). The distance it takes for the air flow to become turbulent is shorter the higher the air velocity is (Siau 1984, Wengert 2006). Thus, too low air velocity gives an unsatisfactory thick boundary layer that delays the drying process.

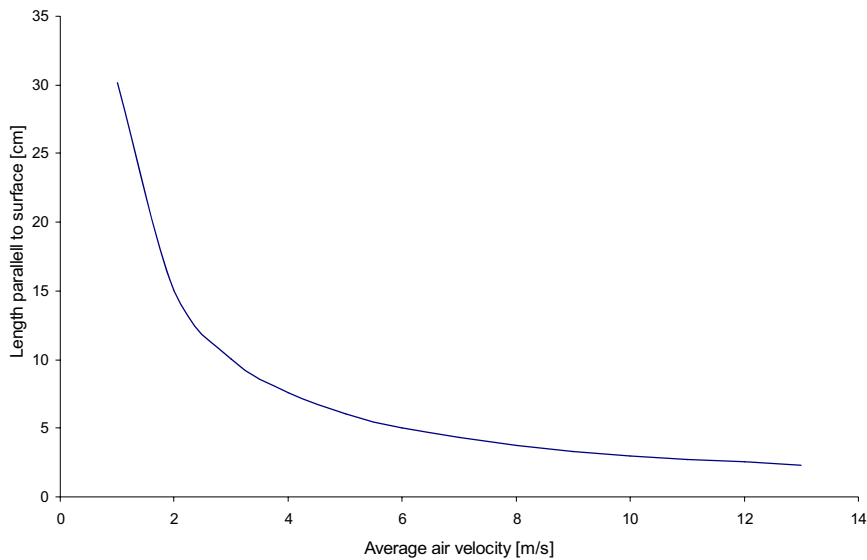

Figure 5. The levels of length parallel to the surface and the air velocity giving turbulent flow (reynolds number=20,000).

1.4 Drying in practice

When considering the whole kiln there are some important factors that make reduction in air velocity difficult. The boards in the kiln have varying initial moisture content. This variation decreases during the drying process but will still affect the needs for air velocity. If one reduces the air velocity when the average moisture content in the batch is appropriate, the drying rate of the boards that have higher moisture content will be reduced, leading to an even greater variation in moisture content (Culpepper 2000). Thus, air velocity must not be lowered to early in the drying process.

When air enters the batch it has a given relative humidity and temperature. As the air passes through the batch the temperature drops and the relative humidity increases, making the drying conditions less favorable for the boards on the out going side (figure 3). This variation increases with the size of the batch but can be reduced by reversing fans (Salin 2001b). With reversing fans both ends gets periods with dry and warm conditions altering with wet and cold periods. This makes the ends more uniform, but in the middle of the batch conditions are still the same as with non-reversing fans, thus variation through the

batch is still present. This variation can be further reduced by higher air velocity supplying more heat and keeping relative humidity at desired level (Salin 2001b).

Another problem in many kilns is the variation in air velocity in the kiln compartment (figure 6). A large variation in air velocity can lead to large variation in final moisture content. The air circulation can be regulated by the kiln compartment design and flaps, to avoid leakage of air at the side of the batch (Riepen & Paarhuis 1999). In a kiln with small variation in airflow there is a potential for reducing air velocity, while in a poorly regulated kiln reduction of air velocity would have to be adapted to the lowest air velocity in the kiln, possibly making it impossible to make any adjustments at all.

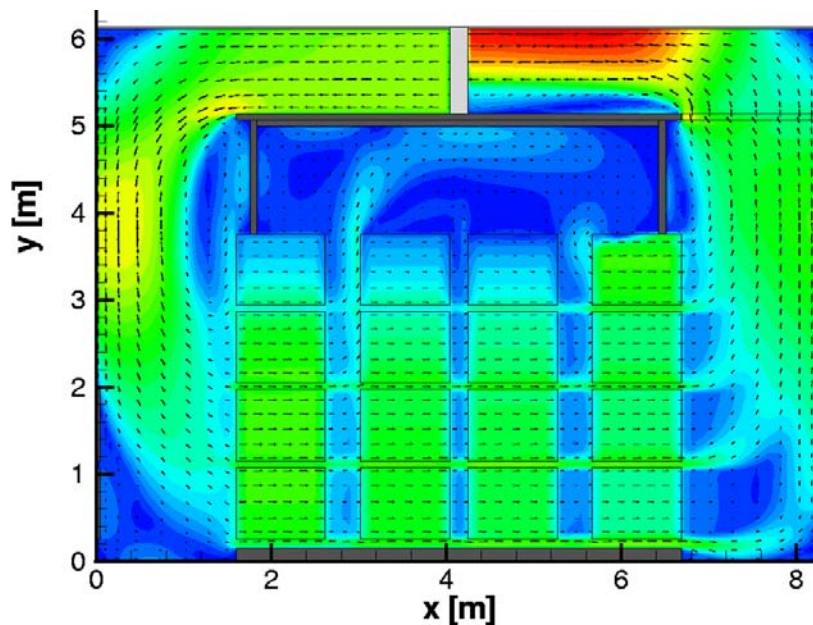

Figure 6. Airflow distribution in an industrial convection kiln showing velocities in the stack from 2 m/s (blue) to 5 m/s (red) (Riepen & Paarhuis 1999).

Sticker thickness is also an important factor in drying of lumber. Thinner stickers allows for more lumber in each batch, but since it is more difficult to obtain the same airflow in the sticker spaces the drying time increases and the variation in final moisture content increases, it is a limit for how thin stickers can be (Salin 2006).

Salin (2001b) also pointed out that when the frequency of the fans is reduced, to reduce air velocity, they produce less heat energy. This loss of energy must be compensated with higher temperature on the radiators, leading to a shift in energy consumption, from electricity to heat rather than a reduction in energy use. Since the prices on energy make it

less expensive to compensate with heat energy this is often preferable (Esping 1992, Vranizan 1986).

How can kiln operators know how to dry their lumber when the drying process is so complicated? Today there are some simulation programs available. One, commonly used in Norway is TORKSIM. In TORKSIM one fills in the wood species, board thickness, initial moisture content, initial temperature, density, air velocity, drying time, and drying schedule. The program then simulates the drying process and gives information about moisture content and stress for an average board (Salin 2001a)

1.5 Need for information

The need for sufficient moisture transport away from the lumber and the implications with the boundary layer sets the conditions for the air velocity. At the same time the decrease of moisture evaporation from the lumber during the drying process allows lower air velocity. The kiln today have more uniform climate and air velocity than earlier and the fans have the possibility for custom-made adjustment throughout the drying. This should result in the possibility to reduce fan speed, without it affecting the drying process. As mentioned before, the focus earlier was to increase air velocity to reduce drying time. Today, when energy prices are increasing and the industry is focusing on what they can do with the environmental changes we are facing in the future, more information about possibilities for reducing energy consumption is needed. To make economically and environmentally optimal decisions in the industry, one needs knowledge about the material itself.

The objectives for this study are to analyze the effects of air flow on drying rate of wood in order to be able to find out when in the drying process and how much the air velocity can be reduced, without it affecting the drying rate of the boards. The materials and methods are intended to represent Norwegian modern lumber drying.

2.0 Materials and methods

Table 1. The variables measured or calculated in the experiment and used in the statistical analysis.

Variable	Denomination	Explanation
Moisture content	%	Calculated moisture content from formula A measured at each time for measurements.
Moisture content group	%	The moisture content for each sample rounded of to the nearest 10 %.
Time	h	Time for each set of measurement of weight during the drying processes
Program	1-7	The different runs in the dryer with the same drying schedule for all but with varying air velocity
Position in dryer	1-6	The position in the dryer for each sample where 1 is closest to the fan and 6 is furthest from.
Board number	1-6	Numbers from 1 to 6 given to the different boards used in the experiments.
Position in board	1-7	The position of the samples from each board, given the numbers from 1 to 7 corresponding to nearest the root to nearest to the top of the stem.
Air velocity	m/s	The average moisture content for the period from the preceding measurement to the actual measurement. (For programs 1-3 the air velocity was measured just before a measurement.
Drying rate	%/h	The average loss of moisture content per hour for the period from the preceding measurement to the actual measurement.

2.1 Material

Six 50 by 100 mm boards (2xlog) of Norway spruce (*L. Karst. Picea abies*) were selected from Romerike Trelast. These boards were cut into seven 500 mm long pieces marked with board number and number of position in the board ascending from root to top (table 1). To avoid a significant influence of end-drying the pieces were sealed at the ends with silicone (Våtromssilikon 193 Essve) (figure 7). The pieces were packed in plastic and put in a freezer to reduce the risk of drying and staining. Before drying the pieces were defrosted in 5 °C over three days. The initial moisture content was later found to be approximately 80 %, and the density 407 kg/m³ (table 1).



Figure 7. The six 50 by 100 mm boards were cut into 500 mm lengths and sealed at the ends with silicone. Numbers refers to board number and position in board.

2.2 Method

The drying experiments were performed in a lab-drying kiln (Brunner Hildebrand) with six board pieces in each run. The samples were placed between two fiberboards and stickers with a thickness of 22 mm (figure 8). Seven programs (table 1) were designed, where all had the same drying schedule but varying air velocity (figure 9). Program 1 had a constant air velocity of approximately 4 m/s, but due to wrong settings in the control system the air velocity was not uphold during the drying. Thus, this program was only used to improve the simulation in TORKSIM with initial moisture content and density, and was later omitted from the statistical analysis. Program 2 had a constant air velocity of approximately 5 m/s and was used as a standard to compare all the other programs with. In programs 3-7 the air velocity started at approximately 5 m/s and was then lowered according to figure 9. To get a result where the reduction of air velocity had a negative effect on the drying rate programs 3, 5, and 6 were constructed as fairly rough programs with an early and large lowering of the air velocity. Program 4 was constructed according to theory with a gradual reduction of air velocity from 40 % to 20 %, where the air velocity was set to a minimum. In case of air velocity having a large effect on drying the air velocity in program 7 was lowered were little. The fiber boards absorbed moisture during the drying programs and was slightly defected (figure 8). This deformation was very small and assumed not to affect the air velocity. During the drying programs the frequency of the

fan was used to control air velocity (table 1). This resulted in slightly different air velocity between the programs, but with the accuracy of the air velocity meter this was assumed not to have a significant effect.



Figure 8. Six samples in each run were placed between two fiberboards and stickers.

To reduce the risk of eventual effect of board number and position in board influencing the effect of program on drying rate, the samples were distributed systematically between the programs. The samples were assigned to the seven programs so that all six boards and all seven positions in the board were represented at least one time in each of the seven programs and each of the six position in the dryer (table 1).

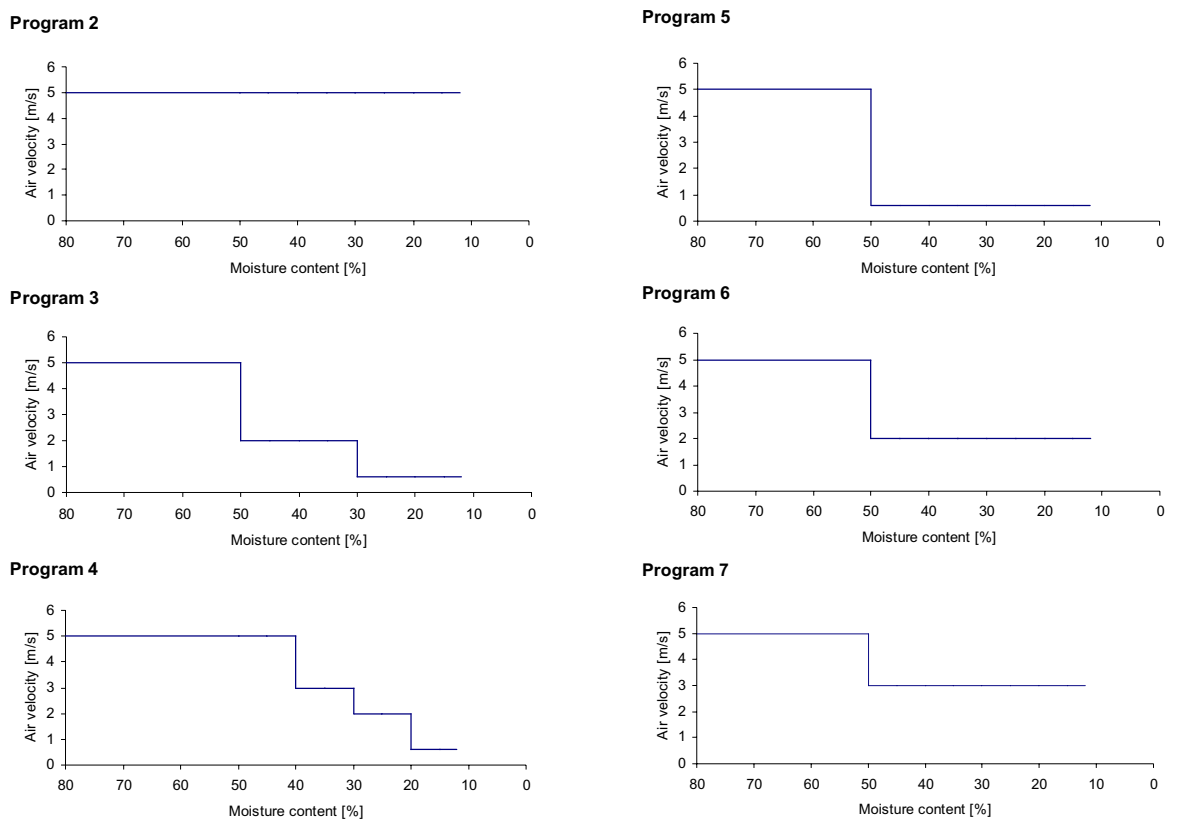

Figure 9. The reduction of air velocity for program 2-7. The moisture content is the expected moisture content according to TORKSIM.

A drying program with 70 °C dry bulb temperature and descending wet bulb temperature was constructed using TORKSIM (figure 10). To see the effect of air velocity also at relatively low moisture content the samples was dried for 96 hours, the time corresponding to 13 % moisture content in the TORKSIM simulation.

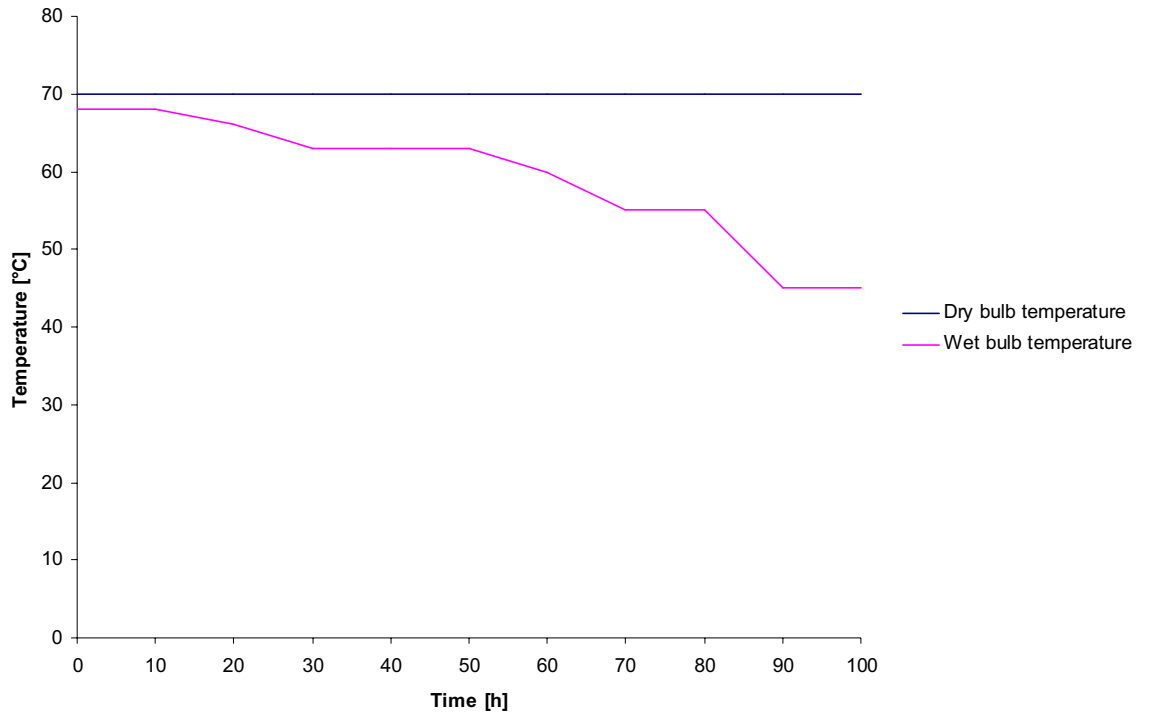

Figure 10. Dry bulb and wet bulb temperature in the experiment.

Air velocity was measured with a VelociCalc Plus 8384A through a hole in one of the upper stickers in the center of the sticker space (figure 11). The VelociCalc Plus is an air velocity meter with a thermal sensor and according to the manual has an accuracy of $\pm 3\%$ or $\pm 0,015$ m/s. The sensor must be placed with the opening perpendicular to the airflow. This was strived for in all setups but could not be fully controlled. Investigations of the spatial variation of air velocity in my setup in the dryer showed it to be small (st.dev. 0,10 m/s). Thus, one measure point was found sufficient. During drying the air velocity was measured throughout the drying process. For program 1-3 a measurement just before weighing the samples, and for program 4-7 air velocity was logged every hour and an average, preceding each weighing, was calculated. Differences between the two methods were small.



Figure 11. The samples shown from the in blowing side with air velocity meter in center of the upper sticker layer.

The samples were weighted before and during drying. For each weighing the six samples were taken out of the dryer and weighted individually. The samples were out of the dryer for about five minutes, and the effect of this was assumed negligible. Times for measuring were determined based on the simulation in TORKSIM. Times corresponding to moisture content of 50, 45, 40, 35, 30, 25, 20, and 13 % from TORKSIM were used.

After each drying the samples were dried in 103 °C for three days to find the absolutely dry weight. The moisture content during drying was then found by:

$$\text{moisture content}_t = \frac{\text{weight}_t - \text{dry weight}}{\text{dry weight}} \times 100 \quad (5)$$

To explain some of the variation between boards basic density was determined for all the samples. The dry weight was measured for a 1-2 cm slice from each sample before they were put into water. After 14 days in water the maximum swelled volume was found by using the “water-dipping” method according to Kučera (1992).

2.3 Statistical analysis

The variation in moisture content over time for the different programs was studied. Different factors (table 1); time, program, density, initial moisture content, position in dryer, board number and position in board, were examined to find good predictors in a model for drying rate. Especially the use of density to explain the same variation as initial moisture content, board number and position in board were considered.

The statistical analysis was made in JMP 5.1. A multiple regression model for drying rate was constructed. This model was used in testing for contrast between program 2 and the other programs to establish if any of these programs differed from program 2. This would mean that in the deviating program air velocity had been reduced too much, leading to an effect in drying rate over time. The programs that did not differ from program 2 would have had an acceptable reduction in air velocity.

To understand the demands for single boards on air velocity a regression fit of drying rate at varying air velocity for different moisture content was made.

3.0 Results

3.1 Moisture content

The moisture content measured over time in the six different programs is presented in figure 12. It decreases rapidly in the beginning of the drying process and levels off in the end. The variation in moisture content between the samples is large in the beginning but reduces down to almost nothing in the end of the drying. None of the six programs with reduced air velocity (3-7) can easily be distinguished from program 2. The rough programs (3, 5, and 6) seem to have a slightly more linear curve than the others, meaning the drying in these rough programs is slightly reduced in the middle of the drying process. When looking at the average moisture content over time for the six programs, there is difficult to distinguish any effect of program on moisture content (figure 13).

If one considers the variation in moisture content in the beginning and at the end of the drying process for the different programs (figure 14), one can see that the variation for program 2 is considerably reduced from start to end. The rough programs, 3, 5, and 6 have not the same reduction in variation. In program 4 and especially program 7, which were programs with relatively modest lowering of air velocity one can see the same reduction as for program 2.

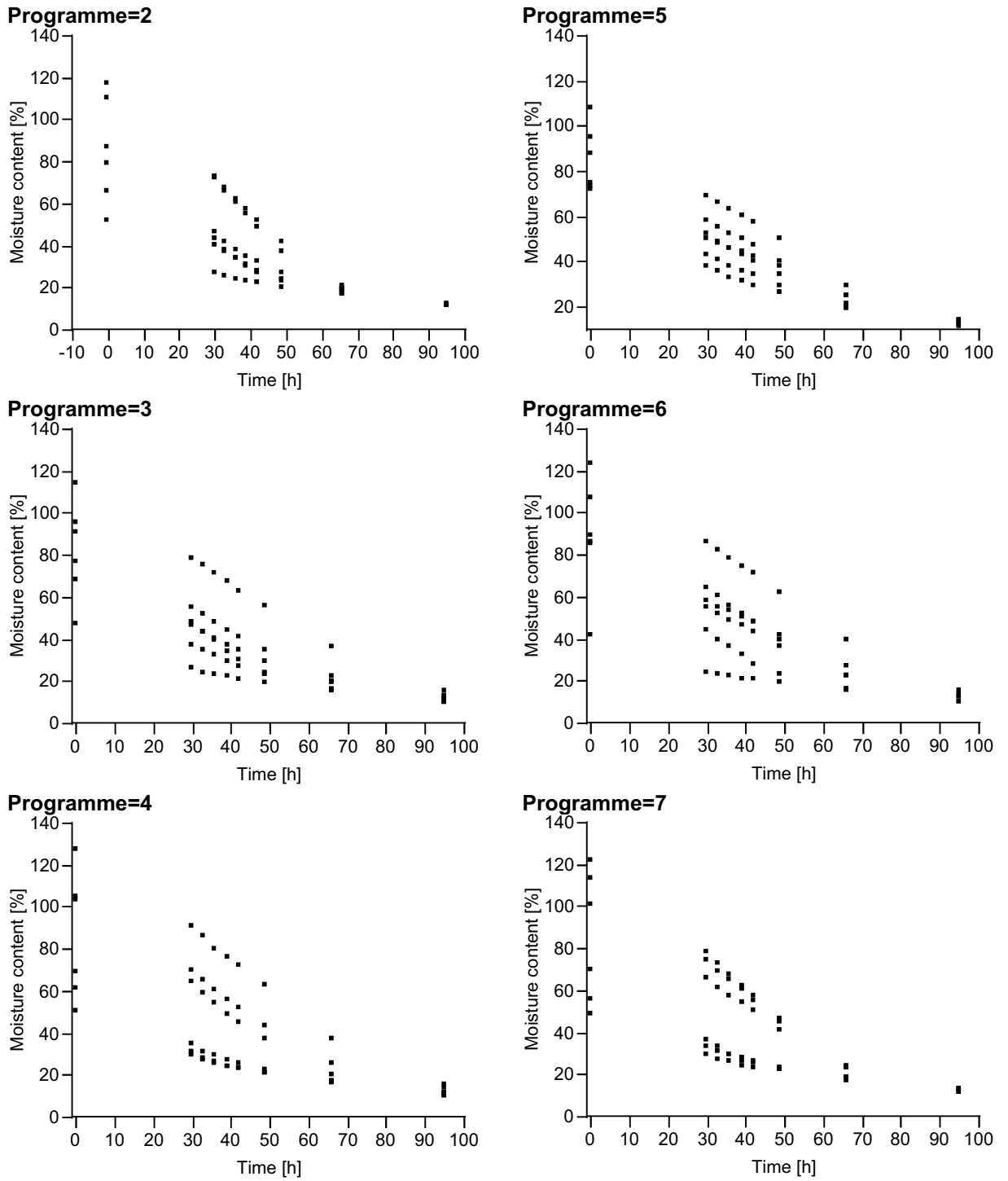

Figure 12. Moisture content over time for six samples in each of the six programs.

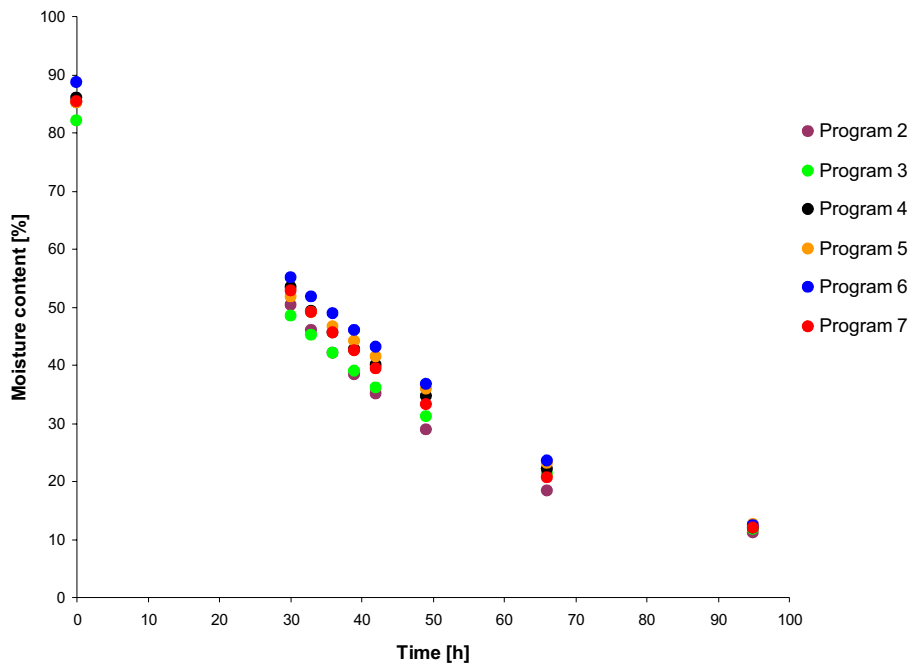

Figure 13. Average moisture content over time for the six programs.

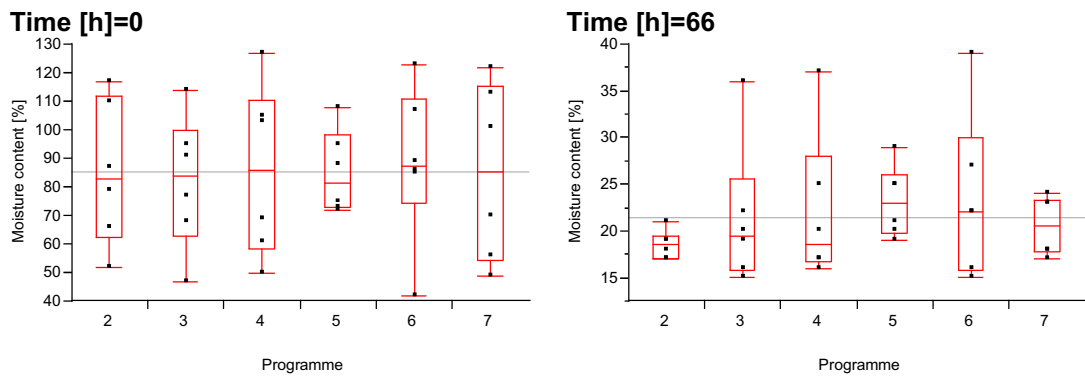

Figure 14. Moisture content for the six programs in the beginning and late in the drying process.

3.2 Drying rate

It is easier to see differences between the programs when considering the drying rate over time (figure 15). It is evident that the relatively rough programs (3, 5, and 6) have reduced drying rate in the measurements between 30 and 40 hours of the drying process.

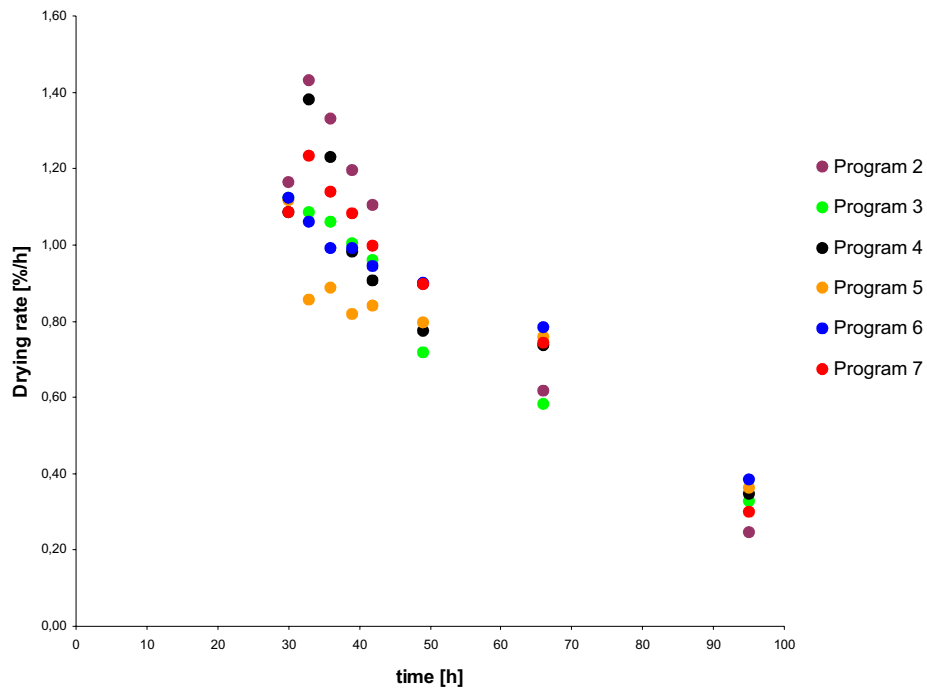

Figure 15. Average drying rate over time for the six programs.

As expected the drying rate decreases with density (figure 16). There were no clear difference in effect of air velocity on drying rate for different levels of density. The distribution of the samples between the six programs was relatively successful. There are no big differences in density between the programs (figure 17).

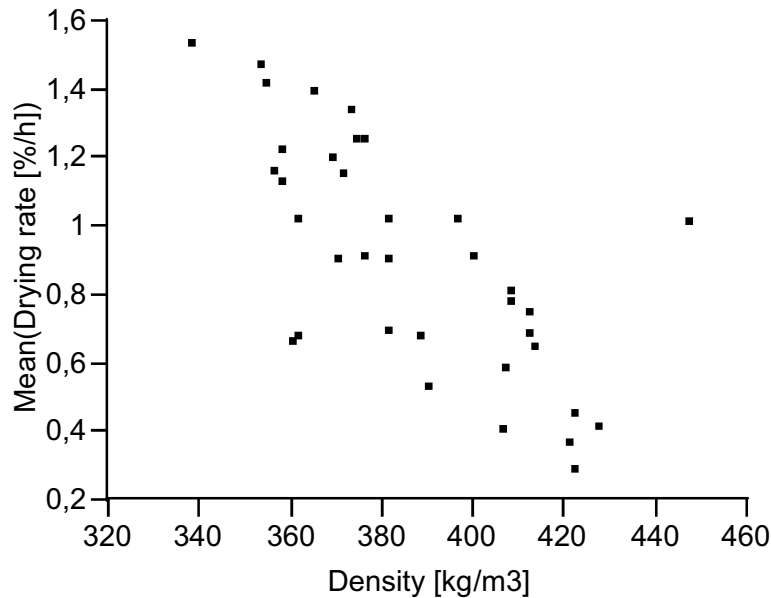

Figure 16. Average drying rate and density for each of the 36 samples.

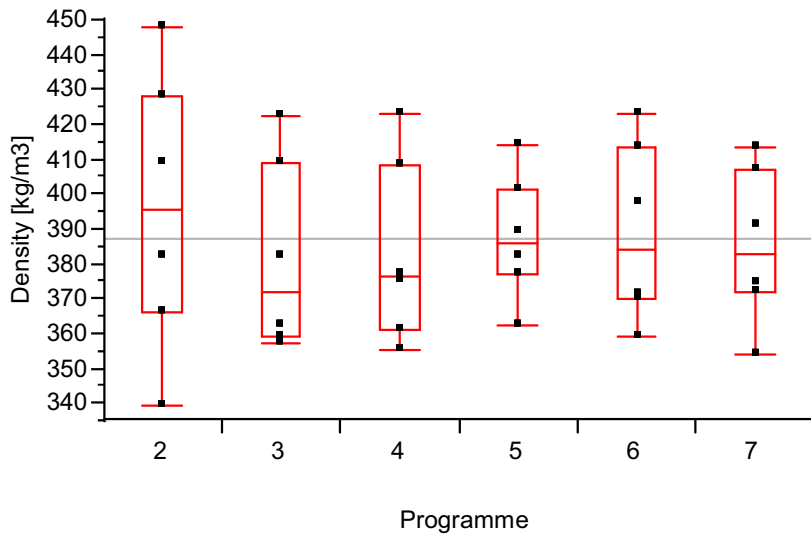

Figure 17. The density of the samples in the six programs.

The different boards dried differently. The plots of the drying rate and density for the different boards (figure 18) show the same pattern but reverse, i.e. the lower the density the higher the drying rate, as shown in figure 16.

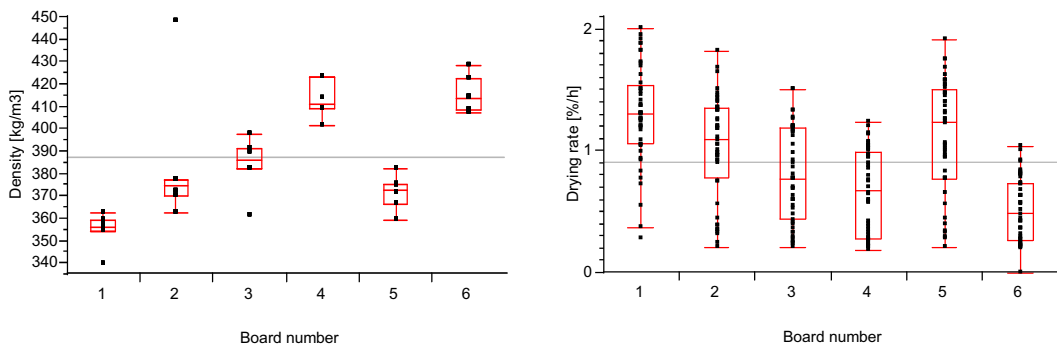

Figure 18. The drying rate and density for the six different boards.

The same plots as for board number for position in board show that the drying rate increases higher in the board and a not so clear trend for density shows that lowest boards have a higher density than the highest (figure 19). Thus, it is the same, but not so clear negative relation between drying rate and density for position in board.

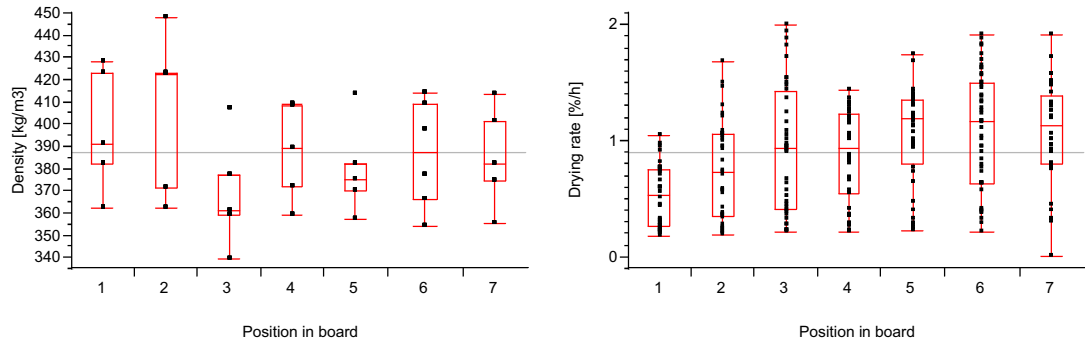

Figure 19. The drying rate and density for the seven positions in the boards.

There was also a clear connection between the drying rate for samples with different initial moisture content and their density (figure 20). High density gives low initial moisture content and high density boards dries slower than low density boards.

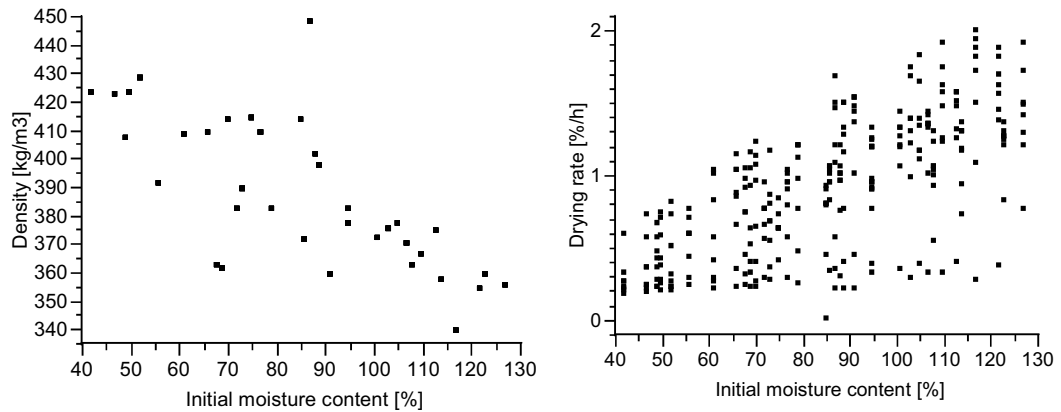

Figure 20. The drying rate and density for varying initial moisture content.

3.3 Multiple regression model for drying rate

A multiple regression model for the drying rate shows that the variables time ($p < 0.0001$), program ($p < 0.0001$), time*program ($p = 0.0005$), board number ($p = 0.0084$), and initial moisture content ($p < 0.0001$) are significant. While position in dryer, position in board, and density are not significant with $\alpha = 0.05$. The fact that density is not significant can be partly explained by the correlation between density and board number and initial content (figures 18 and 20). The model is significant ($p < 0.0001$) (table 3), has an R^2 of 0.81, and a Root mean square error of 0.20 %/h (table 2). Residuals for the predicted values looks randomly distributed around zero, indicating that the model fits the data, except for low values of drying rate, where the model underestimates (figure 21).

Table 2. The R^2 , R^2_{adjusted} , and RMSE for the multiple regression model drying rate = $f(\text{time, program, time*program, board number, initial moisture content})$.

RSquare	0,829
RSquare Adj	0,818
Root Mean Square Error	0,198

Table 3. The ANOVA-table for the multiple regression model drying rate = $f(\text{time, program, time*program, board number, initial moisture content})$.

Source	DF	Sum of Squares	Mean Square	F Ratio
Model	17	51,6	3,03	77,0
Error	270	10,6	0,03	Prob > F
C. Total	287	62,2		<.0001

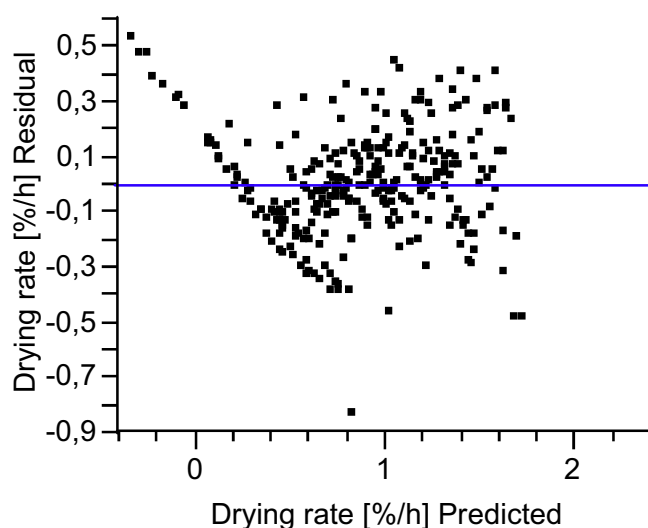

Figure 21. The residual plot for the model drying rate = $f(\text{time, program, program*time, board number, initial moisture content})$.

Contrasts, based on the multiple regression model for drying rate, between the program with constant air velocity (program 2) and the other programs, shows that programs 3, 5 and 6 are significantly ($\alpha=0.05$) different from program 2 (table 4). Programs 4 and 7 are not significantly different but the p-values are still relatively low. Thus, it is difficult to say they have the same drying rate as program 2.

Table 4. The p-values for contrasts between the program with constant air velocity (program 2) and the other programs, using the model; drying rate = $f(\text{time, program, program*time, board number, initial moisture content})$.

Program	3	4	5	6	7
Prob>F Program	0,0190	0,0971	<0.0001	0,0009	0,1453
Prob>F Program*Time	0.0286	0.0792	<0.0001	0.0027	0.0621

3.4 Effect of air velocity on single boards

When one looks at the drying rate for single boards at different moisture content subjected to different air velocities one can see that the drying rate increases for the high moisture contents while the low moisture contents show no influence of air velocity to the drying rate (figure 22). P-values for the effect of the square root of the air velocity on drying rate show that air velocity is not significant for moisture content below 30 %, but for higher moisture content drying rate is significantly influenced by air velocity (figure 22). Thus, there is no evident relation between drying rate and air velocity for moisture content below 30 %.

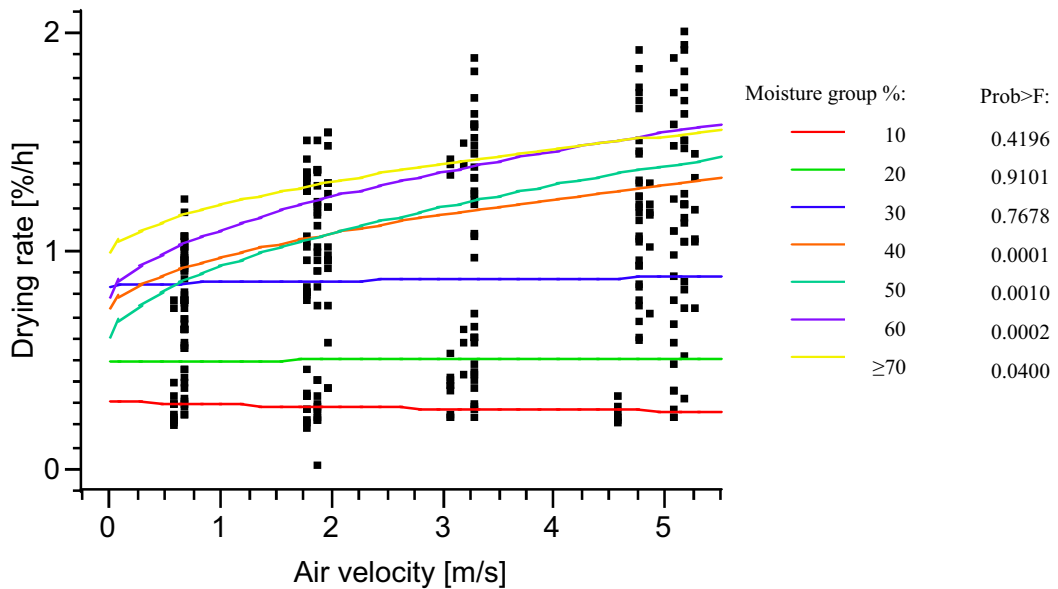

Figure 22. The drying rate at different air velocities for different moisture content with corresponding p-values to the regression fit of drying rate over $\sqrt{(\text{air velocity})}$. Drying rate is the average drying rate up to each measurement, air velocity is the average air velocity up to each measurement, and moisture content is rounded of to nearest 10 %.

4.0 Discussion

4.1 Moisture content

The drying over time is as expected, fast early in the drying process and slows down towards the end. The difference in moisture content variation for the different programs is alarming. A too early reduction in air velocity gives a large variation in moisture content. Because a large variation in moisture content in the lumber is not good for the predictions in lumber quality to early reduction in air velocity is not recommended.

4.2 Effect of air velocity on drying rate for single boards

The results for drying rate at different air velocity for varying moisture content looks very similar to Torgesens (1951) result. No significant effect of air velocity on drying below 30 % moisture content. At 40 % and greater the air velocity is very important at low air velocities and levels off at higher air velocities. It is difficult to distinguish between the effects at higher moisture content. With more observations the trends could possibly have been more differentiated. The result from this regression fit of drying rate at different air velocities is not very clear but they do not contradict any of the earlier findings on the subject (Lamb 2002, Simpson 1997, Wengert 2006), stating that drying rate is dependent upon air velocity at moisture content above approximately 40 % and this effect gradually decreases down to 20 %.

4.3 Effect of air velocity on drying rate for the investigated programs

Drying rate is dependent on density, but since there is a correlation between density and initial moisture content and board number, these variables are not suited to be in the same model as density. There is no significant effect of position in board on drying rate. Possibly it would be greater difference between samples taken with greater distance in the stem. Contrasts based on the multiple regression fit of drying rate indicate that programs 3, 5, and 6 are different from program 2 and therefore air velocity should not be lowered according to these programs. Programs 4 and 7 are not that clearly different from program 2, but their p-values are still low making it difficult to state that they have the same drying

rate as program 2. A small reduction in drying rate does not greatly influence the final moisture content and final moisture content is what is measured as the result of a drying process. Since final moisture content differs very little in my six programs all programs can be considered equal. But looking at spread in moisture content shows that program 3, 5, and 6 give unsatisfactory large variation compared with program 2. This implies that programs 4 and 7 are the only acceptable programs, supporting the result from the contrasts.

4.4 Drying in practice

The variation in initial moisture content explains some of the variation in drying rate. This variation gradually decreases during drying. The difference in moisture content makes it difficult to know when to reduce air velocity without it affecting the dry boards and the wet boards differently. The variation in moisture content in the industrial drying is probably larger than in my experiment. I have only the initial moisture content to consider while in practice there are many more issues that need to be taken in to account.

In this experiment the effect of position in board is not significant. In an industrial kiln the variation between boards in the center of a batch and the ones at the ends can be very large, and this variation increases with batch size. In addition to making a reduction in air velocity difficult because of the difference in moisture content, this moisture content variation is dependent upon the air velocity. To avoid making the variation larger after reducing the air velocity one must always determine the air velocity based on the board with the highest moisture content.

The variation in air velocity in the kiln is also a very important factor. A reduction of air velocity must be adapted to the lowest air velocity in contact with the lumber. If not, one risk some boards being surrounded with saturated air making the drying rate slower.

All these factors make the appropriate reduction of air velocity difficult to determine. It is impossible to make any general assumptions, but one must always consider each kiln individually. In a kiln, with efficient screening of air, good control over the density and initial moisture content, it is possible to reduce air velocity. When considering the reduction in variation in moisture content over time, and the contrasts between program 2 and the other programs, program 4 looks like a program that does not greatly influence the

drying rate but at the same time gives a considerable reduction in air velocity. Thus, a reduction according to program 4 is possible in a “perfect” kiln. In practice it is up to each sawmill to judge how close to “perfect” their kiln is and make, if any possible, appropriate adjustments.

4.5 Practical example

When comparing a drying program with 5 m/s for 100 hours (Program B) with an equally long drying program with decreasing air velocity. For example a program similar to program 4; 5 m/s for 36 hours, 3 m/s for 6 hours, 2 m/s for 24 hours followed by 1 m/s for 34 hours (Program A), the economical potential in reduction of air velocity is evident:

Program A is set to be 100 % electrical energy consumption

In program B the percent of electrical energy used at each level of air velocity compared to 5 m/s is found using equation 1 (table 5).

Table 5. Calculated electrical energy used with different air velocity compared to 5 m/s. Calculations are based on equation 1.

Air velocity [m/s]	Electrical energy used compared to 5 m/s [%]
5	100
3	22
2	6
1	1

Total electrical energy consumption in program B compared to program A is then the sum of energy used compared to 5 m/s (table 5) multiplied by the amount of time each air velocity is held (equation 6).

$$\frac{36 \times 100 + 6 \times 22 + 24 \times 6 + 34 \times 1}{100} = 39\% \quad (6)$$

Thus, one saves about 60 % in electrical energy costs. This is of course only possible in a “perfect” kiln with no variation in moisture content and no variation in air velocity in the kiln. There are no such kilns, but if the kiln operator has good control over the factors influencing the drying process a reduction in air velocity should be possible. Even if only a

reduction down to 2 m/s the final 30 % of the drying time is possible, this results in a reduction in energy use of about 30 %.

One must also take in to consideration the reduction in heat that a reduction in fan speed gives (Salin 2001b). This must be compensated for and the effect must be put into the total cost calculation.

4.6 Future work

The simple practical example shows that there is an economical potential in reducing air velocity and my results show that there is probably room for some reduction in air velocity. This justifies more study on the effects of air velocity, but since there are such big differences between kilns, only laboratory experiments will not be sufficient. Applying the existing theory in practice could give valuable information. Therefore it would be interesting to test the results found in this and other studies in an industrial lumber drying kiln of Scandinavian standard, and find out how big safety margin is needed in a full scale kiln. It should also be tested if different factors, such as wood species, sticker thickness, temperature level, flaps, and screening between packages influence the effect of air velocity on the drying process.

5.0 Literature

Bachrich, J. L. 1980. Dry kiln handbook. Vancouver: H.A. Simons (international) Ltd. ISBN: 0-87930-087-6.

Culpepper, L. 2000. Fan Systems and Airflow. Softwood Drying. San Francisco: Miller Freeman Books. ISBN: 0-87930-581-9.

Eckelman, C. A., Baker, J.L. 1976. Heat and Air Requirements in the Kiln Drying of Wood. Indiana Agricultural Experiment Station Research Bulletin. 933: 3-19

Esping B. 1992. Trätorkning 1a grunder i torkning. Stockholm: Trätekt. ISBN: 91-88170-06-3.

Esping B. 1996. Trätorkning 1b praktisk torkning. Stockholm: Trätekt. ISBN: 91-88170-23-3.

Kučera B. 1992. Skandinaviske normer for testing av små feilfrie prøver av heltre. Skogforsk.

Lamb, F. M. 2002. The Importance of Air Velocity in Drying- How air speed through the kiln affects lumber seasoning. Woodweb ® Inc. Reprinted with permission from Modern Woodworking.

Riepen M., Paarhuis B. 1999. Analysis and Optimisation of the Airflow Distribution in Convection Kilns. COST-E15 Workshop Edinburgh.

Rosenkilde, A. 1996. Measurements of moisture content gradients and surface phenomena during drying of wood. Licentiate thesis. ISBN: 91-7170-740-9

Salin J-G. 2001a. Information transfer to kiln operators in the form of drying simulation models. AB Trätekt, Swedish Institute for Wood Technology Research.

Salin J-G. 2001b. Lufthastighetens inverkan vid kammartorkning. Trätekt. Rapport P0112039.

Salin J. G. 2006. The influence of some factors on the timber drying process, analyzed by a global simulation model. Maderas: Ciencia y tecnologia. 7(3): 195-204.

Siau J. F. 1984. Transport Processes in Wood. Berlin Heidelberg: Springer- Verlag. ISBN: 3-540-12574-4.

Simpson, William T. 1997. Effect of air velocity on drying rate of single eastern white pine boards. (Research note FPL ; RN-0266):5 p. : ill. ; 28 cm.

Torgeson, O. W. 1951. The drying rate of sugar maple as affected by relative humidity and air velocity. Department of Agriculture, Forest Service, Forest Products Laboratory. No. R1264.

Vranizan, J. M. 1986. Thermodynamics of energy use in dry kilns. Proceedings (Western Dry Kiln Association) 37th.

Wengert, E. M. 2006. Principles and Practices of Drying Lumber. Lignomat USA Ltd. Virginia.

Internet:

Statistisk sentralbyrå- statistics Norway 2007 ©: <http://www.ssb.no/indenergi/tab-2007-06-22-05.html>. Last read: 14.05.2008.